

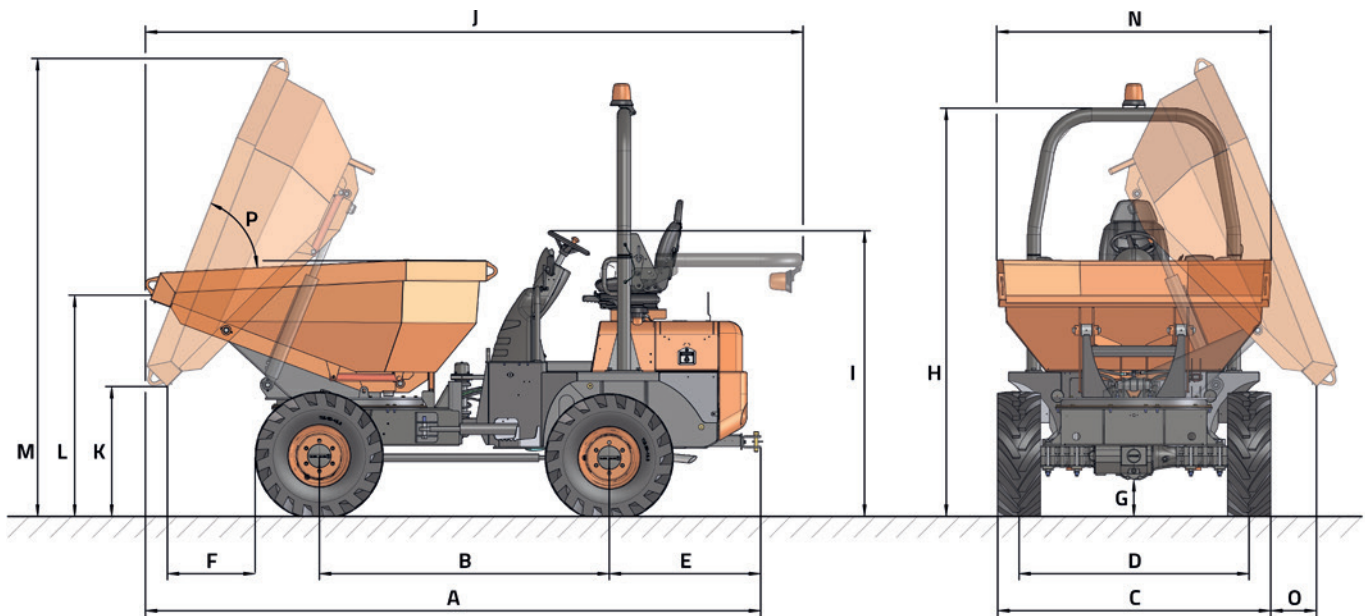

TECHNICAL DATA

GENERAL		D 350 AHG
Unloading system	-	Rotating
Load capacity	lb	7,700
Chassis	-	Articulated and oscillating
Water hopper capacity	cu yd	1.33
Level hopper capacity	cu yd	2.34
Heaped hopper capacity	cu yd	2.78
Empty weight	lb	6,241
Transmission	-	Hydrostatic
ENGINE		
Brand	-	KUBOTA
Model	-	D1803-CR-T-E5B
Power	hp	44
Operating speed	rpm	2,400
Torque	N-m@rpm	150,5@1500
No. of cylinders	-	3
Emissions	-	EPA Tier 4f, Stage V
Injection	-	Common Rail and electronic management
Exhaust aftertreatment	-	DPF (Diesel particulate filter)
Noise	dB(A)	101
DRIVING		
Max. speed	mph	11,8
Maximum gradient	%	54
External turning radius	in	178
Traction	-	4x4
Tyres	-	11.5/80-15.3
HYDRAULIC SYSTEM		
Main pump	-	0.73 cu in gear pump
Flow rate	gal/min	7
Working pressure	psi	2,465
TANK CAPACITY		
Fuel	gal	11.6
Hydraulic system	gal	10.6
BRAKES		
Service	-	Sealed brakes with multiple discs in oil. Hydraulic drive
Parking	-	Sealed brakes with multiple discs in oil. Mechanical drive

DIMENSIONS



DIMENSIONS (in)	D 350 AHG
A	164.2
B	77.2
C	72.4
D	61.2
E	40.4
F	23.6
G	10.2
H	109.1
I	76.4
J	175.2
K	34.3
L	58.7
M	121.7
N	72.8
O	12.2
DIMENSIONS (in)	
P	65



www.ausa.com

Products are subject to modifications without prior notice. Images throughout the spec sheet may refer to non-standard machines or non-available configurations depending on models.

AUSA's logo and corporate identity are property of the Company, they cannot be used without authorization.